

High End automotive woofer.

Precision cast and surface treated magnesium cone coupled to a natural rubber surround showing no sign of midrange (edge) resonances.

Large magnet system with bumped back plate makes room for extreme coil excursions.

Heavy copper rings mounted above and below the T-shaped pole piece reduce non linear and modulation distortion and increase overload margin.

Extremely stiff and stable injection moulded metal basket keeps the critical components in perfect alignment.

Gold plated terminals mounted on a glass fibre reinforced plate reduce contact resistance and improve reliability.

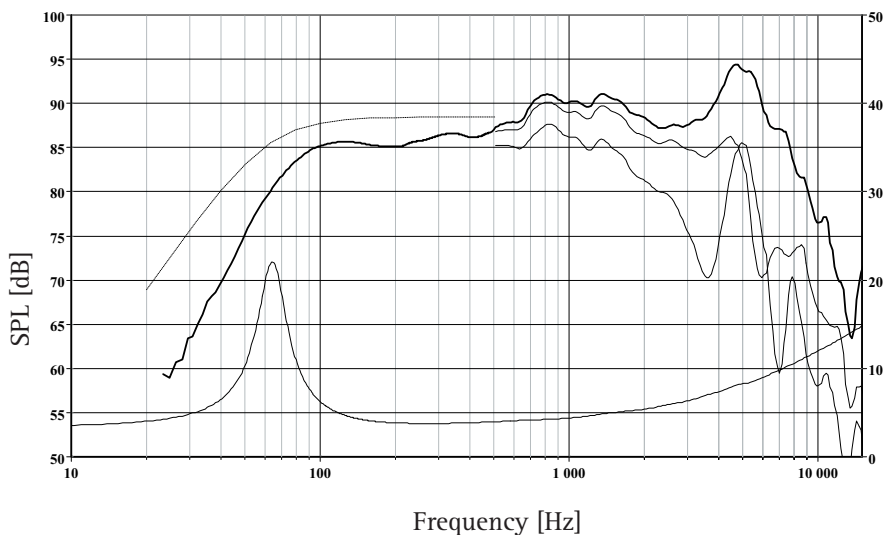

The frequency responses above show measured free field sound pressure in 0, 30, and 60 degrees angle using a 12l closed box. Input 2.83 V_{RMS}, microphone distance 0.5m, normalized to SPL 1m. The dotted line is a calculated response in infinite baffle based on the parameters given for this specific driver. The impedance is measured in free air without baffle using a 2V sine signal.

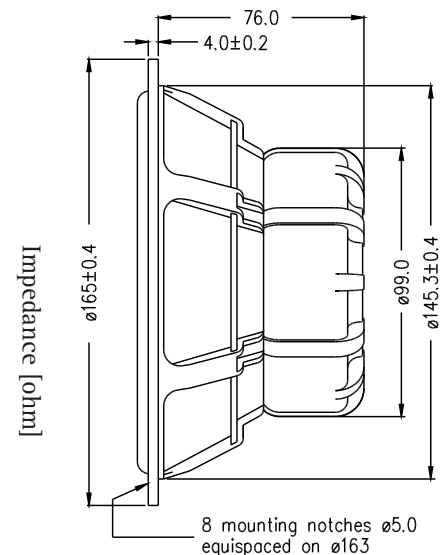

Nominal Impedance	4 Ohms	Voice Coil Resistance	3.2 Ohms
Recommended Frequency Range	50 - 3000 Hz	Voice Coil Inductance	0.45 mH
Short Term Power Handling *	250 W	Force Factor	6.0 N/A
Long Term Power Handling *	100 W	Free Air Resonance	64 Hz
Characteristic Sensitivity (2.83V, 1m)	88.5 dB	Moving Mass	19.0 g
Voice Coil Diameter	39 mm	Air Load Mass In IEC Baffle	0.82 g
Voice Coil Height	14 mm	Suspension Compliance	0.3 mm/N
Air Gap Height	6 mm	Suspension Mechanical Resistance	1.88 Ns/m
Linear Coil Travel (p-p)	8 mm	Effective Piston Area	126 cm ²
Maximum Coil Travel (p-p)	19 mm	VAS	7 Litres
Magnetic Gap Flux Density	0.88 T	QMS	4.24
Magnet Weight	0.42 kg	QES	0.71
Total Weight	1.70 kg	QTS	0.61

*IEC 268-5

Jul 2007-1

SEAS reserves the right to change technical data